

CHEMETRON Fire Systems™ Beta Series Systems with 3M™ NOVEC™ 1230 Fire Protection Fluid

GENERAL INFORMATION

The Chemetron Fire Systems Beta Series Systems are automatic suppression systems using 3M™ Novec™ 1230 Fire Protection Fluid and consisting of four basic components and their associated accessories.

- System Components
- Control Panels
- Detection and Alarm Devices
- Completer Kits

Features

- 1** The system components consist of agent containers, container supports (racks), and discharge nozzles.
- 2** The control panel is the brains of the system and is used to monitor the detection and accessories.
- 3** The detection, alarm devices, and accessories are the external devices that act as the eyes and voice of the system as they give audible or visual signals.
- 4** The completer kits consist of warning signs, hoses, connection fittings, pressure gauges or solenoid valves, and the actuator required to operate the cylinder valve.

The system and its components are agency tested for total flooding applications and should be used in accordance with the guidelines contained in National Fire Protection Association Standard 2001. A total flooding application can be defined as injecting Novec 1230 fluid into an enclosure or volume having the structural integrity to retain the agent during and after discharge. The design of such a system requires that the Novec 1230 fluid be discharged from its container in between a minimum of 5 and a maximum of 10 seconds and be thoroughly mixed throughout the protected volume, reaching a minimum concentration level of 4.2%, but not exceeding 10% in normally occupied spaces.

BETA SERIES SYSTEM EQUIPMENT DESCRIPTION

Cylinder and Valve Assembly

Novec 1230 fluid is stored in specially designed cylinder assemblies. Beta series cylinders are available in three different capacities and are charged with Novec 1230 fluid to a filling density up to 70 lb./ft³ (1121 kg/m³) of cylinder volume. All cylinders are super-pressurized with dry nitrogen to a pressure of 360 psig (2482 kPa), at 70°F (21°C). Each cylinder is equipped with an identification nameplate indicating the quantity of Novec 1230 fluid.

The standard cylinder assembly, having a rigid dip tube, is designed for mounting in a vertical position only. The cylinder assembly is composed of a cylinder, dip tube, and cylinder valve.

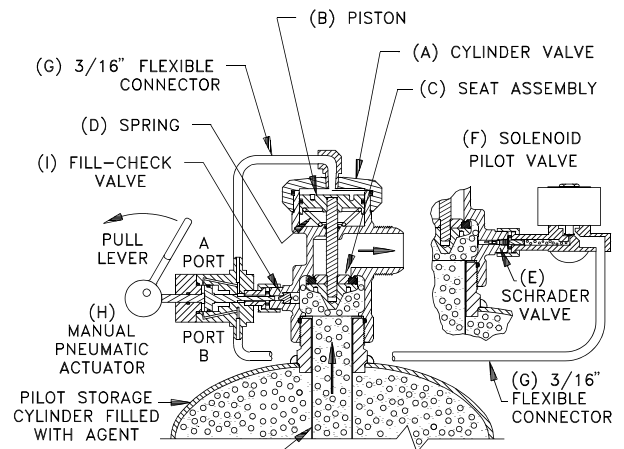
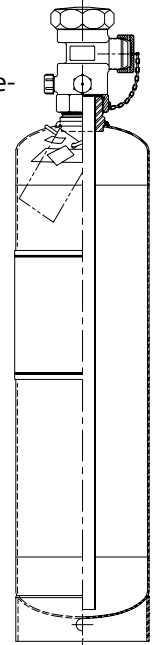

Cylinder Valve -Standby Mode

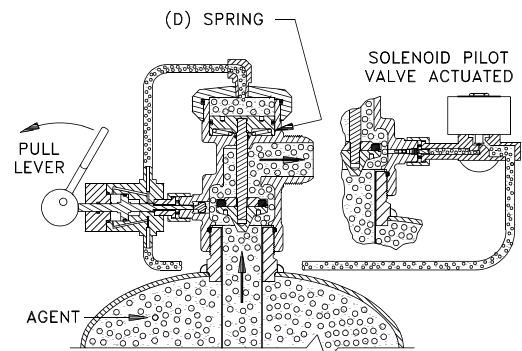

Cylinder Valve -Actuated Mode

CHEMETRON™ Beta Series Systems with Fire Systems™ 3M™ NOVEC™ 1230 Fire Protection Fluid

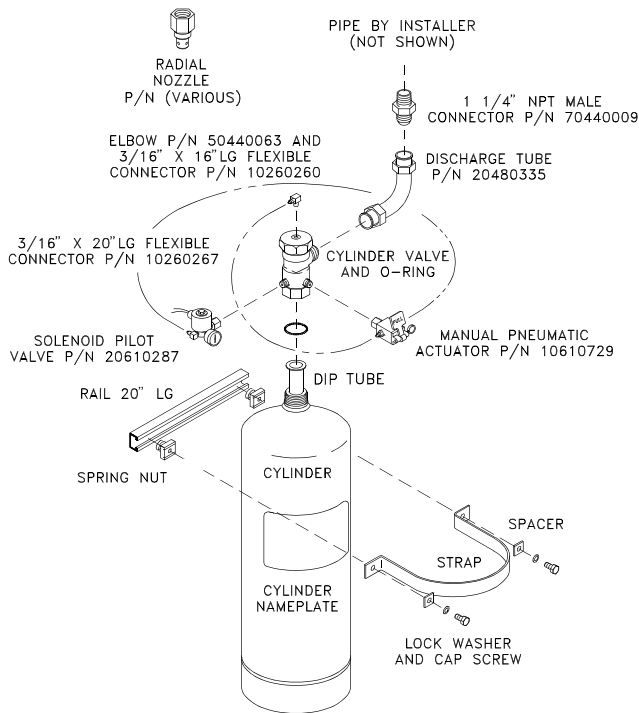

**Beta Series Cylinder Assembly
with Completer Kit, Mounting Bracket & Nozle**

Cylinder	Stock Number	Fill Capacity			
		Minimum		Maximum	
		lb	kg	lb	kg
40 lb.	10481819	21	9.5	41	18.6
55 lb.	10481820	28	12.7	55	24.9
95 lb.	10481821	48	21.8	96	43.5

A Cylinder: The welded seam steel cylinders are manufactured to the requirements of the Department of Transportation (DOT) for compressed gas and have external neck threads for cylinder valve connection.

B Dip Tube: A flanged dip tube extends from the cylinder neck down to within approximately 5/8 in. (16 mm) of the bottom of the cylinder. The flange, clamped between the top of the cylinder neck and the cylinder valve, supports the dip tube.

C Cylinder Valve : A pressure operated cylinder valve having a forged brass body and cap is attached to the cylinder neck and serves to control the flow of Novec 1230 fluid from the cylinder. A synthetic rubber seat disc and disc carrier are connected by a stem to an operating piston at the top. The piston to valve ratio is approximately 3 to 1.

The cylinder valve has five connections, as follows:

1 Manual-Pneumatic Actuator Connection This is a threaded connection housing a check valve and serves as the attachment point for the manual-pneumatic actuator and for cylinder filling operations.

2 Pressure Gauge/Solenoid Pilot Valve Assembly Connection: This is a threaded connection housing a check valve and serves for the attachment of:

- Solenoid pilot valve assembly (with pressure gauge) for pilot cylinders.
- Pressure gauge assembly for all other system cylinders.

3 Safety Disc Connection: A frangible safety disc is connected to the valve body and serves as a pressure relief device to protect the cylinder against excessive internal pressure. Its disc rupture point is in the range of 850 psi to 1000 psi (5860 kPa to 6895 kPa).

4 Discharge Connection: A 1-1/2 in (40 mm) O.D. flare connection serves as the discharge port.

5 Pilot Connection: A 1/4 in (8 mm) NPT tap in the cylinder valve cap provides a means of applying pilot pressure above the operating piston.

COMPLETER KIT COMPONENTS

Either a primary or slave completer kit is required to complete the installation of each Novec 1230 fluid filled cylinder. The components included in the primary and slave completer kits are detailed in the following chart.

CHEMETRON Fire Systems™ Beta Series Systems with 3M™ NOVEC™ 1230 Fire Protection Fluid

Description	Completer Kits	
	Primary 20480780	Slave 20480781
	Quantity	Quantity
Solenoid valve	1	0
Solenoid valve with supervisory pressure switch	1*	0
Discharge tube	1	1
Manual-pneumatic actuator	1	0
3/16" flex hose 16" long	1	1
3/16" flex hose 20" long	1	1
90° Elbow 1/4" FI x 1/4" MNPT	1	3
1-1/4" Male connector	1	0
1/4" Male connector	0	1
Pressure gauge	0	1
Pressure gauge with supervisory pressure switch	0	1*
Warning sign	1	0
Operating instruction nameplate	1	0
* Items are part of the Primary (S/N 20480782) and Slave (S/N 20480783) Completer Kits with Supervisory Pressure Switch		
If cylinders are used in a Main/Reserve system, order decals: Main Decal - S/N 50360753 Reserve Decal - S/N 50360752		

Solenoid Pilot Valve Assembly

The system utilizes a solenoid pilot valve assembly to provide pilot pressure for actuation. The solenoid must be electrically supervised by a recognized fire suppression system control panel.

The solenoid pilot valve assembly includes a pressure gauge and adapter with swivel nut, vented elbow, and O-ring seal that is attached to the pressure gauge connection of the cylinder valve.

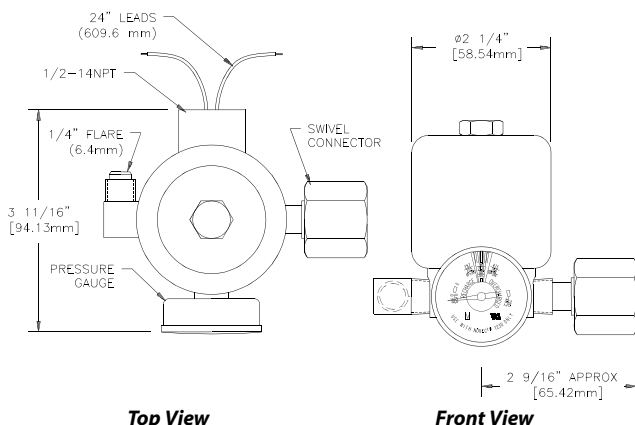

Stock Number	Description
20610287	Solenoid pilot valve assembly 120V-60Hz/24VDC
20610307	Explosionproof Solenoid pilot valve assembly 24 VDC
20610288	Solenoid pilot valve assembly with supervisory pressure switch 120V-60Hz/24VDC

Manual-Pneumatic Actuator - S/N 10610729

This device is required for the manual actuation of a cylinder and is attached to a check valve connection port. This is a dual purpose device, having an actuating piston connected to a pin to upset the fill check valve when pilot pressure is applied to the piston. With the check valve open, cylinder pressure is applied through the pilot connection to the operating piston of the Beta valve, thereby opening the cylinder to discharge its contents.

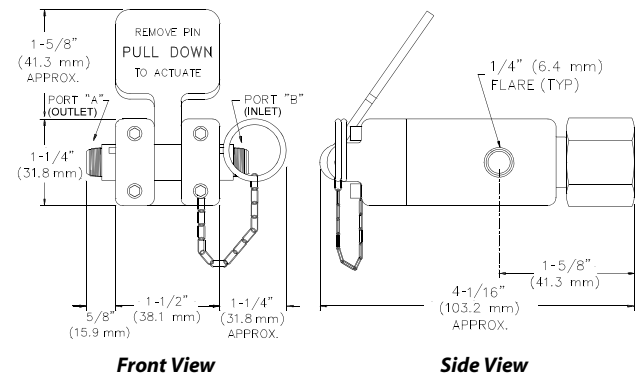

Discharge Tube Assembly - S/N 20480335

A formed, 1-1/2 in. (40 mm) O.D. steel tube assembly with a flare nut at each end is used to connect the cylinder valve to a male connector, which can then be connected to the discharge piping system.

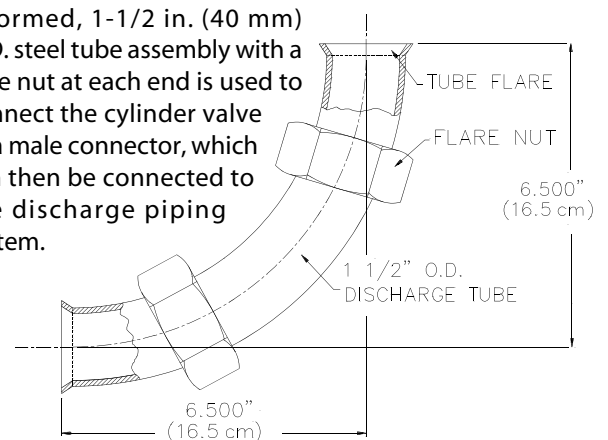

CHEMETRON Fire Systems™ Beta Series Systems with 3M™ NOVEC™ 1230 Fire Protection Fluid

Discharge Connection Fitting - S/N 70440009

A 1-1/4 in. (32 mm) male connector is used to attach a cylinder to the discharge piping system.

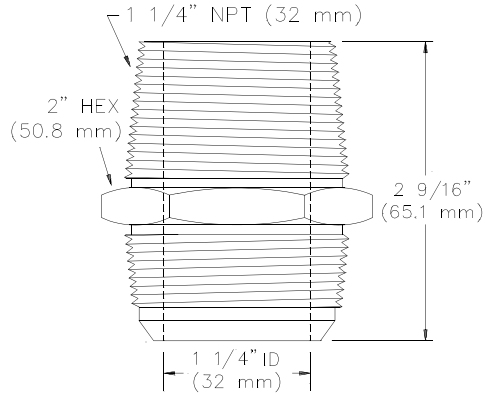

Flexible Connector

Lengths of 3/16 in. (5 mm) flexible connectors are used to interconnect the cylinder valve devices. These hoses have a stainless steel wire braid cover and a teflon liner, and are fitted at each end with a 1/4 in. swivel flare nut.

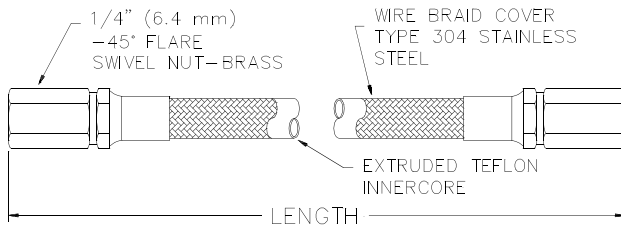

Stock Number	Description
10260260	3/16 in. (5 mm) Connector 16 in. (40.6 cm) long
10260267	3/16 in. (5 mm) Connector 20 in. (50.8 cm) long
10260303	3/16 in. (5 mm) Connector 28 in. (71.1 cm) long

Pressure Gauge Assembly

In systems requiring more than one cylinder, a pressure gauge assembly is required for each cylinder other than the pilot cylinder as a means of visual surveillance of the pressure condition within the cylinder.

Stock Number	Description
20240046	Pressure Gauge Assembly
20240047	Pressure Gauge Assembly w/supervisory pressure switch

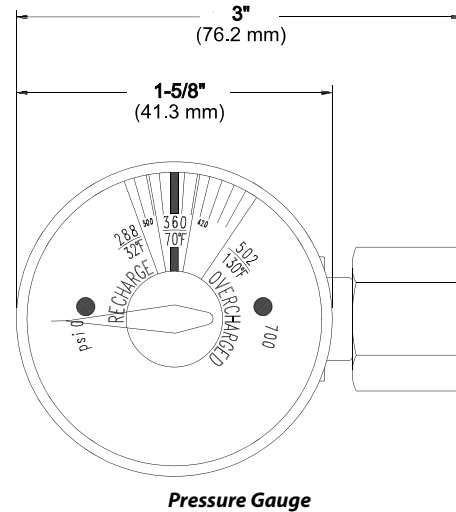

OPTIONAL EQUIPMENT

Pressure Switch

A pressure switch is used in the system to implement the shut down of power and various items of equipment, such as fans; and for annunciation and alarm purposes. An explosionproof pressure switch is also available.

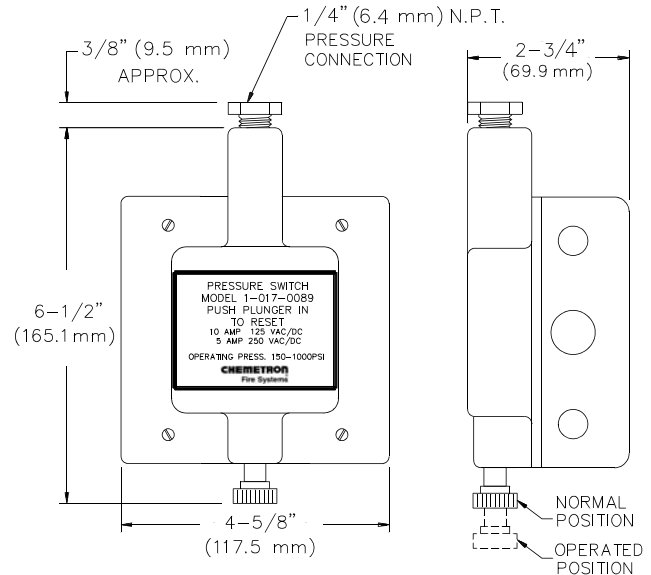

Stock Number	Description
10170089	2 Pole Pressure Switch <i>indoor use only</i>
70170229	Explosionproof 2 Pole Pressure Switch
10170065	4 Pole Pressure Switch <i>weatherproof</i>

CHEMETRON Fire Systems™ Beta Series Systems with 3M™ NOVEC™ 1230 Fire Protection Fluid

Check Valve - S/N 10610732

A check valve is used between the cylinder valve discharge outlet flexible connection and the discharge manifold. The check valve prevents back flow from the manifold in the event that the system is discharged when one or more cylinders are disconnected, such as for weighing or general servicing. A check valve is not required on single cylinder systems.

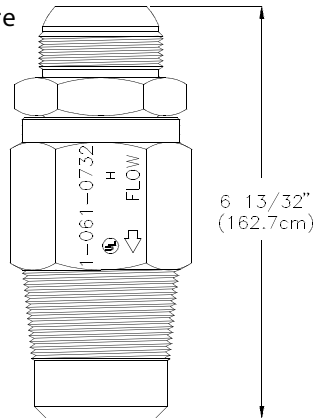

CYLINDER RACK

Single/Multiple Cylinders, Vertically Mounted S/N 20710268

The cylinder rack, consisting of a rail, a strap, and miscellaneous hardware for interconnection, is shipped unassembled. The rail is provided with 1-1/8 in (2.85 cm) slots on 2 in (5.0 cm) centers for mounting bolts.

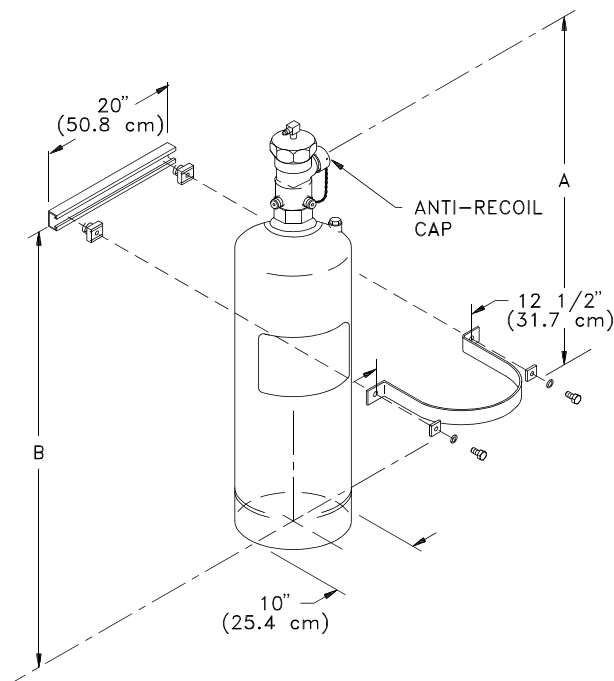

Stock Number	Nominal Cylinder Size	Dimension			
		A		B	
		in	cm	in	cm
10481819	40 lb.	20 1/2	52.1	12 1/4	31.1
10481820	55 lb.	25 3/8	64.4	14	35.5
10481821	95 lb.	38 5/8	98.1	22 3/4	57.8

Stock Number	Empty Cylinder Weight Lb (Kg)	Cylinder Assembly Dimensions			
		Height		Diameter	
		in	cm	in	cm
10481819	38 (17)	23 5/16	60.4	10	25.4
10481820	50 (23)	28 1/8	71.4	10	25.4
10481821	65 (30)	41 3/8	105.1	10	25.4

NOZZLES

Nozzles (8 port) are used to control the flow of Novec 1230 fluid to insure it is discharged in between a minimum of 5 and a maximum of 10 seconds and properly distributed in the protected hazard.

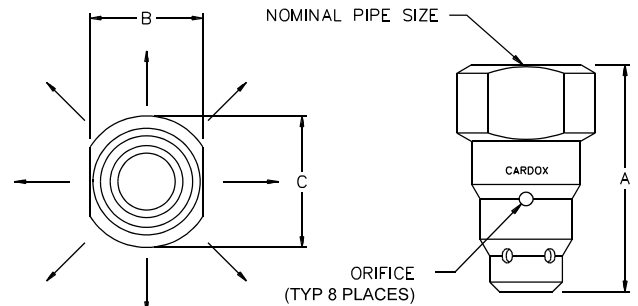

360 Degree Radial Nozzle for use with Novec 1230 fluid

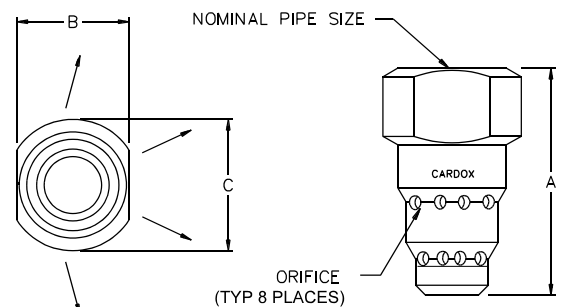

180 Degree Sidewall Nozzle for use with Novec 1230 fluid

CHEMETRON™ Fire Systems™ Beta Series Systems with 3M™ NOVEC™ 1230 Fire Protection Fluid

Stock Number		Nominal Pipe Size	Nozzle Height	
			A	
Stainless	Brass		in	mm
360° Radial Nozzle				
10371360	10371415	3/8 in (10 mm)	2.031	51.6
10371361	10371416	1/2 in (13 mm)	2.250	57.2
10371362	10371417	3/4 in (19 mm)	2.688	68.3
10371363	10371418	1 in (25 mm)	2.875	73.0
10371364	10371419	1-1/4 in (32 mm)	3.250	82.6
10371365	10371420	1-1/2 in (38 mm)	3.625	92.1
10371366	10371421	2 in (51 mm)	4.500	114.3
180° Sidewall Nozzle				
10371452	10371438	3/8 in (10 mm)	2.031	51.6
10371453	10371439	1/2 in (13 mm)	2.250	57.2
10371454	10371440	3/4 in (19 mm)	2.688	68.3
10371455	10371441	1 in (25 mm)	2.875	73.0
10371456	10371442	1-1/4 in (32 mm)	3.250	82.6
10371457	10371443	1-1/2 in (38 mm)	3.625	92.1
10371458	10371444	2 in (51 mm)	4.500	114.3

PHYSICAL/CHEMICAL PROPERTIES

Novec 1230 fluid [(CF₃CF₂C(O)CF(CF₃)₂)] is a compound that consists of carbon, fluorine and oxygen. It is colorless, odorless, electrically non-conductive, and suppresses fire by interrupting the combustion process and affecting the available oxygen content in the area of the discharge.

Novec 1230 fluid is clean, efficient, listed as "acceptable" by the U.S. Environmental Protection Agency (EPA), and leaves no residue, thus minimizing any downtime after a fire.

If exposed to temperatures greater than 1067°F (575°C), toxic products of decomposition (hydrogen fluoride) are formed. The system should be designed to discharge between a minimum discharge time of 5 seconds and a maximum discharge time of 10 seconds. The amount of toxic byproducts formed during extinguishment of flames is greatly reduced by discharging the agent in less than 10 seconds. Most materials contained in areas protected by Novec 1230 fluid, such as aluminum, brass, rubber, plastics, steel, and electronic components, are unaffected when exposed to Novec 1230 fluid.

Novec 1230 fluid is stored as a liquid in steel containers and superpressurized with nitrogen to 360 psig (2482 kPa) to increase its discharge flow characteristics. When discharged, Novec 1230 fluid will vaporize at the discharge nozzles and effectively mix with the air throughout the protected area.

SAFETY CONSIDERATIONS

In accordance with NFPA Standard 2001 and the EPA Significant New Alternative Program (SNAP), personnel exposure to total flooding system concentrations of Novec 1230 fluid shall be limited to the following:

The discharge of Novec 1230 fluid into a hazard may cause a reduction in visibility for a brief period. Any direct contact with the agent can cause frostbite.

A cylinder containing Novec 1230 fluid should be carefully handled. **All anti-recoil devices must be in place at all times when the cylinder is not restrained.**

The Material Safety Data Sheet (MSDS) covering Novec 1230 fluid should be read and understood prior to working with the agent.

Concentration Level	Exposure Restriction
10% or below (current NOAEL)	No restriction
Greater than 10% (current LOAEL)	Avoid any exposure

The seller makes no warranties, express or implied, including, but not limited to, the implied warranties of merchantability and fitness for a particular purpose, except as expressly stated in seller's sales contract or sales acknowledgment form. Every attempt is made to keep our product information up-to-date and accurate. All specific applications cannot be covered, nor can all requirements be anticipated. All specifications are subject to change without notice.

CHEMETRON™
Fire Systems™
A World of Protection



4801 Southwick Drive
Third Floor
Matteson, IL 60443
708/748-1503 • FAX 708/748-2847